



DISCAL[®]

MICRO-BUBBLE AIR SEPARATORS

CALEFFI
Hydronic Solutions



Heating & Cooling

Components for today's modern hydronic systems



Smart
Solutions, Inc.
High Performance Building Products

208-798-4449

PRODUCT FEATURES

- **Anti-rotation/anti-vibration pinned float:**
Creates space between float and air vent wall to prevent float hang-up from debris or variations in separator installation orientation.
- **Large-diameter chamber:**
Slows fluid flow dramatically. Combines with concentric, sharp-edged mesh design to cause micro-bubbles to efficiently collect and coalesce. Highly effective automatic air elimination.
- **Anti-corrosion coalescing mesh:**
Constructed of glass-filled nylon. More resistant to dissolved oxygen and acidic fluids than plated metals.
- **Robust stainless steel float linkages:**
Reliable float alignment even during turbulent conditions such as filling from bottom.
- **Corrosion resistant:**
All components highly resistant to hydronic chemical additives or unstable pH fluid.
- **Optional service check valve:**
Allows expansion tank removal without purging system.

High performance, long-lasting air elimination

Dissolved oxygen and other gasses within hydronic systems can cause excessive corrosion and sediment formation. The Caleffi DISCAL[®] micro-bubble coalescing air separator with high discharge capacity and unique chamber design, automatically and efficiently rids system gasses. A very robust design and 100% anti-corrosion components enable DISCAL[®] to provide a long, trouble free life.

PRODUCT RANGE - DISCAL®

SIZES	MAX. FLOW RATE: (GPM)*	CODE				
		NPT	SWEAT	PRESS	NPT COMPACT**	SWEAT COMPACT**
3/4"	6	551005A(C)	--	--	551003A(C)	551022A(C)
1"	10	551006A(C)	551028A(C)	551066A(C)	--	--
1 1/4"	15	551007A(C)	551035A(C)	551067A(C)	--	--
1 1/2"	22	551008A(C)	551041A(C)	551068A(C)	--	--
2"	39	551009A(C)	551054A(C)	551069A(C)	--	--

*4 feet per second fluid velocity.
 **SST mesh.
 (C) automatic 1/2" service check valve included.



PERFORMANCE

MAX. WORKING PRESSURE	150 psi (10 bar)
WORKING TEMPERATURE RANGE	32 – 250°F (0-120°C)
MAX. PERCENTAGE OF GLYCOL	50%
AIR SEPARATION EFFICIENCY	up to 100%

CONSTRUCTION

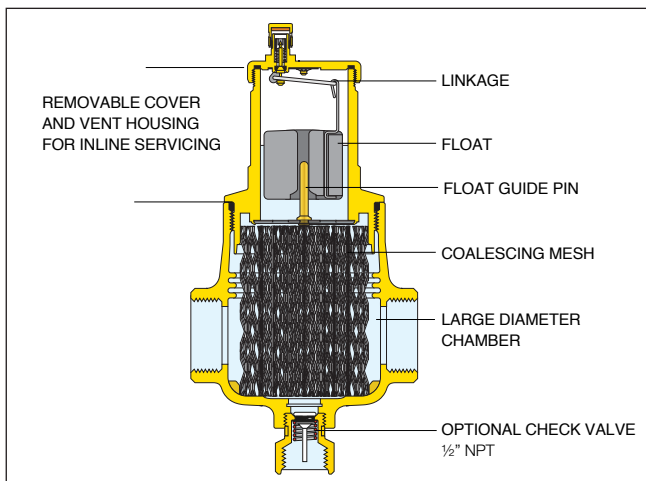

APPLICATION DIAGRAM

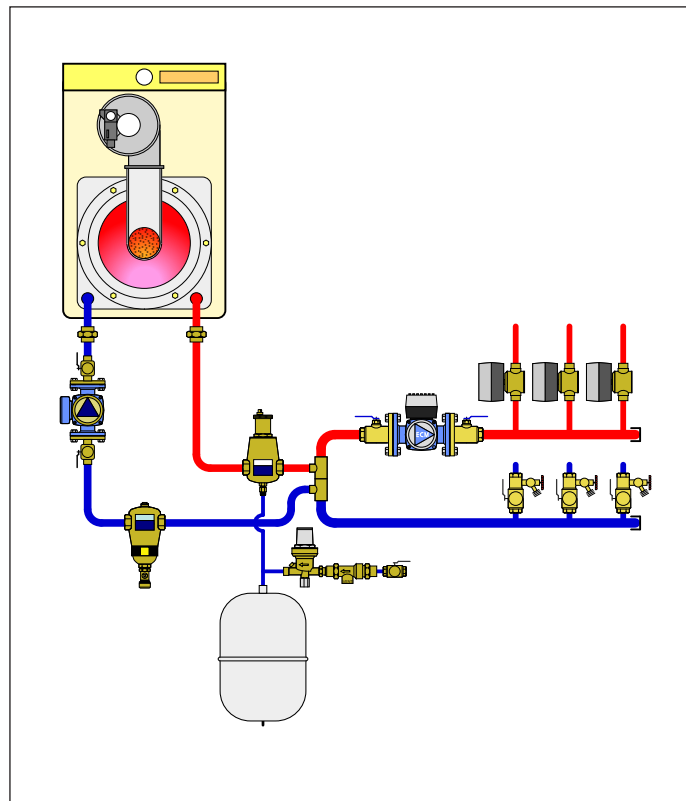

Caleffi Partner:



CALEFFI
Hydronic Solutions

03603-18 NA

WE RESERVE THE RIGHT TO CHANGE OUR PRODUCTS AND THEIR RELEVANT TECHNICAL DATA, CONTAINED IN THIS PUBLICATION, AT ANY TIME AND WITHOUT PRIOR NOTICE.

Caleffi North America, Inc.
 sales@caleffi.com · www.caleffi.com
 © Copyright 2018 Caleffi North America, Inc.